

# TECHNICAL SPECIFICATIONS

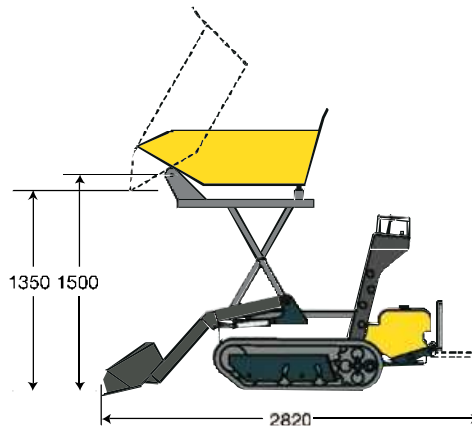
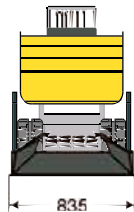
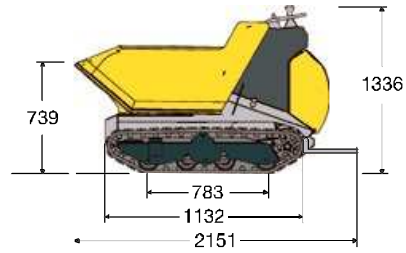

## [ WEIGHT ]

	POWER	POWER+	HI TIP	HI TIP+
Operating weight	560 kg	665 kg	670 kg	770 kg

## [ ENGINE ]

Type	LN 100 AE
Fuel	Diesel
Net power	10 HP

## [ HYDRAULIC SYSTEM ]

Transmission	Hydrostatic
Hydraulic pumps	2 pumps with variable flow for the translation 1 pump with fix flow for the equipment

## [ PERFORMANCE ]

Max. travelling speed	4 km/h
Payload	800 kg
Dump vessel capacity - struck (POWER)	0,34 m <sup>3</sup>
Dump vessel capacity - heaped (POWER)	0,45 m <sup>3</sup>
Dump vessel capacity - struck (POWER+, HI TIP, HI TIP+)	0,28 m <sup>3</sup>
Dump vessel capacity - heaped (POWER+, HI TIP, HI TIP+)	0,36 m <sup>3</sup>

## [ UNDERCARRIAGE ]

Track width	180 mm
Type	Track rollers